

Code : 13PS1205

M.TECH. DEGREE EXAMINATION, SEPTEMBER 2014

M.Tech. II Semester**ADVANCED POWER SYSTEM PROTECTION
(Power Systems)**

Time : 3 hours

Max. Marks :60

*Answer FIVE Questions, Choosing ONE Question from each section
All Questions carry equal marks*

* * *

SECTION - I

- 1 a With relevant wave forms discuss about coincidence type phase comparator. 6
- b Derive the General Equation of Amplitude comparator. 6
- 2 What is an impedance relay? Explain its operating principle. Discuss how it is realised using the: 12
- i) Electromagnetic principle
- ii) Amplitude comparator
- iii) Phase comparator.

SECTION - II

- 3 a Explain the duality between amplitude and phase comparator 6
- b How does the static directional relay help in discrimination in protection of (i) Parallel feeder (ii) Ring mains. 6
- 4 a Explain the circulating type amplitude comparator and Integrating type phase comparator 6
- b Explain the realization of reactance relay using a sampling comparator. 6

SECTION - III

- | | | |
|---|---|----|
| 5 | Explain various types of static over current relays with vector diagram and applications. | 12 |
| 6 | What is carrier current protection? For what voltage range is it used for the protection of transmission lines? | 12 |

SECTION - IV

- | | | | |
|---|---|--|----|
| 7 | a | Explain about harmonic restraint relay | 6 |
| | b | Describe about analysis of static differential relays | 6 |
| 8 | | Explain the schemes of pilot wire relaying employing (i) circulating current method (ii) voltage balance method. | 12 |

SECTION - V

- | | | | |
|----|--|---|----|
| 9 | | Draw the basic block schematic diagram of interface for directional relay and also draw the flow chart for the microprocessor based directional relay | 12 |
| 10 | | How can a quadrilateral distance relay be realised using a microprocessor? | 12 |

M.TECH. DEGREE EXAMINATION, SEPTEMBER 2014

M. Tech. II Semester

WIRELESS COMMUNICATIONS

(Digital Electronics & Communication Systems)

Time : 3 hours.

Max. Marks : 60

*Answer FIVE Questions, Choosing ONE Question from each Section
All Questions carry equal marks*

* * *

SECTION - I

1. Give all specifications and details of WLL.
2. Write about all specifications and features of Bluetooth.

SECTION - II

3. Explain in detail parameters of Mobile multipath channels.
4. Give Ricean distribution for small scale fading.

SECTION - III

5. What are diversity techniques and explain Time diversity techniques?
6. How to measure the performance of Rayleigh fading channel?

SECTION - IV

7. What is handoff and give details of any two handoff techniques?
8. Give performance metrics of a RAKE receiver.

SECTION - V

9. What is the capacity of a flat fading channel?
10. Explain about Multiple Input Multiple Output (MIMO) systems.

Code : 13MME201

M.TECH. DEGREE EXAMINATION, SEPTEMBER 2014

M.Tech. II Semester

**QUALITY ENGINEERING IN MANUFACTURING
(Advanced Manufacturing Systems)**

Time : 3 hours

Max. Marks :60

*Answer FIVE Questions, Choosing ONE Question from each section
All Questions carry equal marks*

* * *

SECTION - I

- 1 (a) Explain the importance of quality engineering in design production process.
(b) Suppose you are manufacturing green paint. To determine a specification for the pigment, you must determine both a functional tolerance and customer loss. The functional tolerance, Δ_0 is a value for every product characteristic at which 50% of customers view the product as defective. The customer loss, A_0 , is the average loss occurring at this point. Your target is 200g of pigment in each gallon of paint. The average cost to the consumer, HomePainto, is \$10 per gallon from returns or adjusting the pigment. The paint becomes unsatisfactory if it is out of the range $200g \pm 10g$. Calculate the loss imparted to society from a gallon of paint with only 185g of pigment.
- 2 (a) Explain Quality Loss Function for Various Quality Characteristics in detail?
(b) What are types of tolerances explain in detail?

SECTION - II

- 3 (a) Define hypothesis and illustrate the formulation for hypotheses using a practical example.
(b) Explain with a model two -way ANOVA and one-way ANOVA

4 Write an algorithm for four level factors of ANOVA with an example.

SECTION - III

5 (a) What is the role of quality engineering in product design?

(b) Distinguish between external, internal and unit-to-unit noise factors.

6 (a) Identify and explain three noise factors that may affect the functioning of a laser printer.

(b) How the F-test gives the factor effects which are statistically significant?

SECTION - IV

7 (a) What are the various interpretation methods used in orthogonal arrays?

(b) How number of experiments to be carried out will be eliminated by orthogonal arrays?

8 (a) What are the test strategies used in orthogonal arrays?

(b) Give the procedure adopted in conducting and analyzing the experiments orthogonal arrays.

SECTION - V

9 (a) What makes Six Sigma seem successful? Explain in detail

(b) How the Six Sigma improves the Quality of Production?

10 (a) How to apply the Six Sigma MAIC discipline into each individual critical factor of your Six Sigma QMS.

(b) What is the best ways to learn about the process improvement? Explain in detail.

Code : 13CS1201

M.TECH. DEGREE EXAMINATION, SEPTEMBER 2014

M.Tech. II Semester

**ADVANCED COMPUTER NETWORKING
(Computer Science & Engineering)**

Time : 3 hours

Max. Marks :60

*Answer FIVE Questions, Choosing ONE Question from each section
All Questions carry equal marks*

* * *

SECTION - I

- 1 Explain the design issues of Network Layers
- 2 Explain the ATM reference model? How it is different from OSI Model ?

SECTION - II

- 3 Explain the CSMA/CD protocols in detail
- 4 Give a Hamming code for the data 1101 ? What is the actual string transmitted? Suppose the 3rd bit from the left is inverted explain how it is corrected at the receiver?

SECTION - III

- 5 Explain the operation of transparent bridges with a suitable example
- 6 Give the format of ARP packet? Explain the operation of ARP

SECTION - IV

- 7 Explain the different types of distributed structures?
- 8 Explain the client server model in detail

SECTION - V

- 9 Explain the concept of concurrency
- 10 Differentiate between Authentication, Authorization? Explain the different authentication methods.

M.TECH. DEGREE EXAMINATION, SEPTEMBER 2014

M.Tech. II Semester**POWER SYSTEM DYNAMICS & STABILITY
(Power Systems)**

Time : 3 hours

Max. Marks :60

Answer **FIVE** Questions, Choosing **ONE** Question from each section
All Questions carry equal marks

* * *

SECTION - I

- 1 (a) Explain the major assumptions behind the classical model of a power system. Derive the Swing equation.
- (b) A generator is connected to an infinite bus through an external impedance $Z_e=0.1+j0.2$. The generator is represented by a voltage source $E_g \angle \delta$ in series with a reactance x_g . If $E_g=E_b=1.0$, $x_e=-0.5$, $x_g=0.3$ for $P_b=1.0$ p.u.. Find the equilibrium values of δ in the range of $(-\pi, \pi)$. Test their stability. Assume infinite bus angle as zero.
- 2 (a) Explain the equal area criterion for determining stability of a single machine infinite bus system.
- (b) A single machine is connected to a load centre through a transmission line as shown in Figure 1. The load centre is represented by a reactance connected to an infinite bus. The generator is initially operating with $P_e=1.0$ p.u. and the magnitudes of voltages V_1 and V_2 are 1.0 p.u. each. Find the maximum step increase in the mechanical power that will not cause transient instability. Use equal area criterion. Assume $x_g=0.5$, $x_t=0.2$, $x=0.4$, $x_2=0.1$

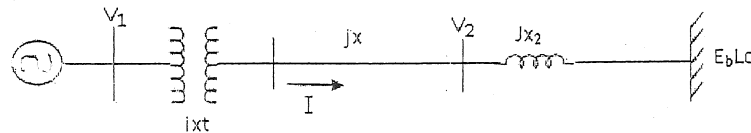

Fig. 1

SECTION - II

- 3 (a) Starting from the torque equation, derive the transformed torque equation of the synchronous machine using park's transformation.
- (b) Explain how stator and Rotor Base quantities are chosen in a synchronous machine.
- 4 (a) Starting from the Voltage equations, derive the transformed voltage equation of the synchronous machine using park's transformation.
- (b) What is the advantage of Power Invariant Transformation? Prove that the Power Invariant transformation is orthogonal.

SECTION - III

- 5 (a) What are the distinct types of excitation systems? Explain Type AC1 alternator-rectifier excitation system with block diagram
- (b) Derive the state equations of IEEE type1 excitation system with block diagram representation.
- 6 (a) Explain static excitation system with block diagram and derive its state equations
- (b) Derive the state equations from transfer functions.

SECTION - IV

- 7 Derive the simplified stator and rotor equations of the synchronous machine used in analysis of dynamic performance.
- 8 (a) With the help of phasor diagram, explain the procedure for the calculation of initial conditions of the synchronous machine equations.
- (b) A generator is connected to an infinite bus through an external impedance of jx_e . If $E_b=V_{t0}=1.0$ p.u. $P_t=1.0$ p.u. Find the initial conditions. Assume $x_e=0.25$ p.u. The generator data: $x_d=1.8$, $x_q=1.7$, $x'_d=0.17$, $x'_q=0.23$, $R_a=0.0$, $T'_d=0.4$ sec, $T'_q=0.1$ sec, $H=4$ sec, $f_B=60$ Hz.

SECTION - V

- 9 (a) Explain small signal analysis with block diagram representation.
- (b) Explain representation of Flux delay and Excitation system with the help of block diagram.
- 10 (a) Considering synchronous machine system without AVR, derive the stability criterion from the synchronizing and damping torque analysis.
- (b) Explain the function of power system stabilizer and the various control signals used as inputs to the stabilizer.

M.TECH. DEGREE EXAMINATION, SEPTEMBER 2014

M.Tech. II Semester

**DIGITAL COMMUNICATION TECHNIQUES
(Digital Electronics & Communication Systems)**

Time : 3 hours

Max. Marks :60

*Answer FIVE Questions, Choosing ONE Question from each section
All Questions carry equal marks*

* * *

SECTION - I

1. Explain about digital PAM modulation method with waveforms and derive the expression for energy of M PAM signals also draw the signal space diagram for M=16? 12
2. (a) Explain signal space concepts. 6
(b) Explain matched filter receiver. 6

SECTION - II

3. Derive the expression for Probability of error for M-ary PSK? 12
4. Explain KarhunenLoeve expansion approach and whitening? 12

SECTION - III

5. Explain Rayleigh and Ricean fading channels? 12
6. Why fading is not desired one and explain fading in multipath channels? 12

SECTION - IV

7. Explain decision feedback equalization? 12
8. Explain Nyquist criterion for zero – ISI? 12

SECTION - V

9. Explain Multichannel and Multicarrier Systems? 12
10. Compare the performance of BPSK, QPSK, FSK, DPSK, and MSK? 12

M.TECH. DEGREE EXAMINATION, SEPTEMBER 2014

M.Tech. II Semester
RAPID PROTOTYPING
(Advanced Manufacturing Systems)

Time : 3 hours

Max. Marks :60

Answer FIVE Questions, Choosing ONE Question from each section
All Questions carry equal marks

* * *

SECTION - I

1. (a) What is product life cycle? What is the role of rapid prototyping (RPT) in this context?
(b) Explain in detail the common information workflow indicating the main stages of RP systems workflow
2. (a) Explain stereo lithography process with a neat sketch.
(b) Discuss on STL files and Define slicing relevant to CAD.

SECTION - II

3. a How FDM (Fusion Decomposition Modeling) is used in RPT? What are the applications of FDM models?
b Explain shape deposition manufacturing.
4. a Explain the principle operation of solid ground curing.
b What are the merits and demerits of laminated Object manufacturing?

SECTION - III

5. a With a neat sketch explain Selective Laser Sintering.
b Differentiate SLA and SLS in Rapid prototyping
6. a Describe 3D printing process with a neat sketch
b Write short notes on Object Quadra system.

SECTION - IV

7. a Explain in detail the LENS process with a neat diagram. Also write the advantages and disadvantages.
b What are heterogeneous objects?
8. a What is Rapid Tooling and explain about shell investment casting process with its advantages and disadvantages.
b Write short notes on Aluminum filled epoxy tooling,

SECTION - V

9. a Explain Vacuum casting with suitable diagram?
b Write the applications of vacuum casting process.
10. (a) Explain various methods of surface generation from point cloud.
(b) Explain file formats for data transfer in RPT

Code :13CS1202

M.TECH. DEGREE EXAMINATION, SEPTEMBER 2014

M.Tech. II Semester

**SERVICE ORIENTED ARCHITECTURE
(Computer Science & Engineering)**

Time : 3 hours

Max. Marks :60

*Answer FIVE Questions, Choosing ONE Question from each section
All Questions carry equal marks*

* * *

SECTION - I

1. Explain about Software platforms for enterprise Applications.
2. Write short note on OSI, TCP/IP and ATM Models.

SECTION - II

3. (a) Explain about Service integration with ESB.
(b) Write about benefits of SPA.
4. (a) Explain briefly about the Design Activities of SOA.
(b) What is a Business Case? Explain the Business Case of SOA.

SECTION - III

5. (a) Discuss about SOA governance.
(b) Explain about Process Orchestration.
6. Explain the Trends in SOA.

SECTION - IV

7. (a) Explain about XML Security.
(b) Explain about XML Signature.
8. Explain about Advanced Messaging in SOA?

SECTION - V

9. (a) Write about SOA Research Issues.
(b) Explain about WS-Security.
10. Explain in detail about Protocols and Coordination.

M.TECH. DEGREE EXAMINATION, SEPTEMBER 2014

M.Tech. II Semester**PRODUCTION & OPERATIONS MANAGEMENT
(Advanced Manufacturing Systems)**

Time : 3 hours

Max. Marks :60

*Answer FIVE Questions, Choosing ONE Question from each section
All Questions carry equal marks*

* * *

SECTION – I

1. Explain the application of concurrent engineering in manufacturing industry with suitable example.
2. (a) What are the current issues in production management?
(b) Explain different approaches of product development in detail.

SECTION – II

3. (a) Explain steps in product life cycle.
(b) Consider the following assembly network relationships of a product. The number of shifts per day is 2 and the number working hours per shift is 8. The company aims to produce 48 units of the product per day. Group the activities into work stations using Ranked Positional weight method and compute Balancing Efficiency.

Activity	1-2	1-3	2-6	3-4	3-5	4-6	5-6	5-7	6-7
Duration (min)	4	6	8	7	4	6	5	9	10

4. (a) What is value engineering? Explain methodology.
(b) Consider the following assembly network relationships of a product. The number of shifts per day is 2 and the number working hours per shift is 8. The company aims to produce 80 units of the product per day. Group the activities into work stations using Ranked Positional weight method and compute Balancing Efficiency.

Operation No.	1	2	3	4	5	6	7	8	9	10
Immediate Preceding tasks	--	1	1	1	2, 3	3, 4	5	5, 6	4, 6	7, 8, 9
Duration (Minutes)	7	2	2	5	8	3	4	7	9	8

SECTION – III

5. (a) What are the strategies in aggregate planning?
 (b) Explain the suitability of JIT production in automobile industry.
6. (a) Explain transportation model of aggregate planning.
 (b) Explain Kanban system in manufacturing industry with suitable example.

SECTION – IV

7. (a) Explain John's rule and its extension.
 (b) Find the sequence that minimizes the total elapsed time required to complete the following tasks. Table gives the processing times in hours. Calculate idle time also.

Job	A	B	C	D	E	F
M1	2	6	9	3	2	4
M2	10	8	10	7	9	12

8. (a) Differentiate job shop and flow shop scheduling.
 (b) Use graphical method to minimize the time needed to process the following jobs on machines A, B, C, D, and E. Find the total time elapsed to complete both jobs.

Job 1	Sequence	A	B	C	D	E
	Time (hrs.)	4	3	6	2	7
Job 2	Sequence	D	C	A	B	E
	Time (hrs.)	6	3	5	3	7

SECTION – V

9. A small project is composed of time activities whose time estimates are given below.

Activity	Predecessor	Estimated duration (weeks)		
		Optimistic	Most likely	Pessimistic
A	--	2	2	8
B	--	2	5	8
C	--	4	4	10
D	A	2	2	2
E	B	2	5	14
F	C	3	6	15
G	D&E	2	5	8
H	D&E	5	8	11
I	F&G	3	6	5

- a) Find the expected duration and variance of each activity.
- b) Calculate the slack for each activity
- c) What is the expected duration? Determine the variance and standard deviation of the project.
- d) If the project due date is 28 days what is the probability of not meeting the due date.
- e) What should be the project duration for the probability of completion of 95%

10 (a) The table below gives precedence relationships and the durations of various activities

Predecessor Activity	A	B	C	D	E	F	G	H	I	J	K	L	M	
Successor Activity	--	--	A	B	A	C, D	B	E	C, D, E	E	F, H, I	C, D, G	J	
Duration (days)	T ₀	6	7	20	1 4	10	10	12	16	12	1	7	17	7
	T _m	10	10	22	1 5	12	12	14	18	14	2	9	19	8
	T _p	12	12	25	1 7	15	14	18	21	17	3	11	22	10

- i) Draw the network and identify the critical path
- ii) What is the probability of completing the project in 57 days.

(b) What do you mean by project crashing? Explain the procedure involved in crashing.

Code : 13CS1203

M.TECH. DEGREE EXAMINATION, SEPTEMBER 2014

M.Tech. II Semester

**SOFTWARE ARCHITECTURE
(Computer Science & Engineering)**

Time : 3 hours

Max. Marks :60

*Answer FIVE Questions, Choosing ONE Question from each section
All Questions carry equal marks*

* * *

SECTION - I

1. What is software architecture? Discuss supporting design levels.
2. Discuss the procedure for building ABC. List out and Explain supporting influences to and from architectures.

SECTION – II

3. List out and explain the types of architectural styles with example.
4. Discuss the role of integration in software development environments with example.

SECTION – III

5. Briefly explain the list of design spaces and supporting rules with example.
6. Explain in detail how pattern supports software architecture.

SECTION – IV

7. Write short notes on architectural description languages.
8. List out and explain the requirements and qualities of OMA? Discuss the purpose of ADL.

SECTION – V

9. Discuss the organizational implications of a product line. Explain component based systems.
10. How to achieve architecture from architecture to system?

M.Tech. II Semester

**AI TECHNIQUES IN POWER SYSTEMS
(Power Systems)**

Time : 3 hours

Max. Marks :60

Answer **FIVE** Questions, Choosing **ONE** Question from each section
All Questions carry equal marks

SECTION - I

- 1 (a) Explain in detail the working of biological neuron and compare with artificial neural networks.
(b) Write a brief description on the characteristics of neural networks.

Find the region where $O_5=1$ if the activation function used is bipolar binary.

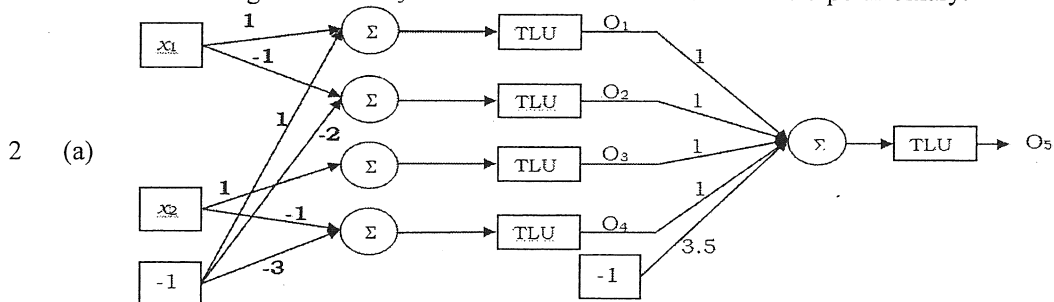

- (b) What are the various neural networks architectures? Give a brief description about them.

SECTION - II

- 3 Explain the typical three layer feed forward network with back propagation training algorithm with all necessary equations.
4 (a) Explain the Single Layer Discrete Perceptron Training Algorithm (SDPTA) and give its summary.
(b) What are the limitations of perceptron model? Explain with X-OR gate.

SECTION - III

- 5 (a) What are the different encoding techniques? Explain about the following encoding techniques with an example:
i. Hexadecimal Encoding

ii. Tree Encoding

What is Cross Over? Explain the following cross over operations in genetic algorithm:

- (b) i. Single-site Cross Over
 ii. Uniform Cross Over

- 6 (a) Explain the convergence of generic algorithm.
 (b) What are the various mutation operators? Explain them briefly.

SECTION - IV

Explain the following basic Fuzzy set operations with examples.

- 7 (a) i. Union & Intersection
 ii. Product of two Fuzzy sets
 iii. Product of a Fuzzy set with a Crisp number
 (b) Explain different types of relations in Crisp sets.
 8 (a) Explain the max-min composition in Crisp sets with an example.
 (b) Explain the max-min composition in Fuzzy sets with an example.

SECTION - V

- 9 Explain briefly about Speed control of dc and ac motors using the fuzzy logic approach.

10 Convert the following three fuzzy sets \tilde{A}_1, \tilde{A}_2 & \tilde{A}_3 and aggregation of these fuzzy sets into crisp sets using the following methods:

- i. Centriod method
 ii. Centre of sums method
 iii. Mean of maxima method

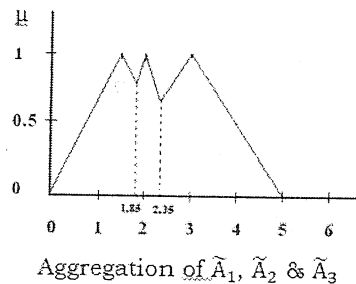
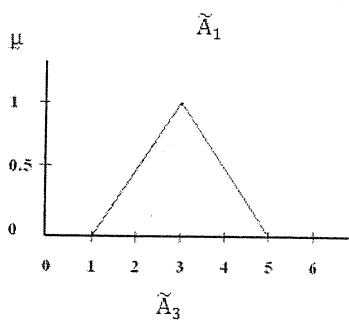
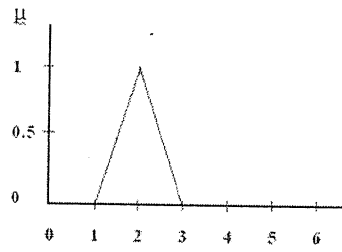
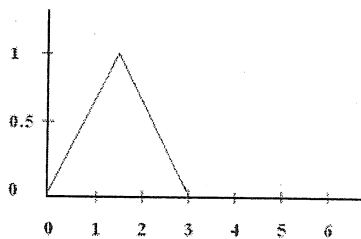

Aggregation of \tilde{A}_1, \tilde{A}_2 & \tilde{A}_3

Code: 13EC1203

M.TECH DEGREE EXAMINATION, SEPTEMBER 2014

**M.TECH. II SEMESTER
MODERN RADAR SYSTEMS**

(Digital Electronics & communication Systems)

Time: 3 hours

Max. Marks: 60

Answer **FIVE** Questions, Choosing **ONE** Question from each section
All Questions carry equal marks

* * *

SECTION – I

- 1 (a) Draw the block diagram of basic radar system and explain its operation.
(b) Explain about detection of signals in noise.
- 2 (a) What is clutter? Explain about volume clutter and obtain an expression
For detection of range in volume clutter.
(b) Define active jamming. Derive the expression for radar range with active jamming..

SECTION – II

- 3 (a) Explain in detail about detection of fluctuating targets.
(b) Explain about the necessity of matched-filter.
- 4 (a) Explain about Sequential detection with rapid confirmation.
(b) Write short notes on CFAR detection.

SECTION – III

- 5 (a) Explain in detail about amplitude comparison mono pulse tracking system.
(b) Explain about conical scanning.
- 6 Write short notes on:
(a) Angle measurement (b) Sector Scan.

SECTION - IV

- 7 Explain about Synthetic aperture radar.
- 8 Write short notes on
(a) 3D radar (b) HF over the Horizon Radar.

SECTION – V

- 9 (a) Explain about Electronic Counter Counter Measures.
(b) Explain about detection range in noise jamming.
 - 10 (a) Write Short notes on objectives of ECM.
(b) Explain about tracking radar.
-

M.TECH. DEGREE EXAMINATION, SEPTEMBER 2014

M.Tech. II Semester

**VOLTAGE STABILITY
(Power Systems)**

Time : 3 hours

Max. Marks: 60

*Answer FIVE Questions, Choosing ONE Question from each section
All Questions carry equal marks*

* * *

SECTION - I

- 1 Explain voltage stability analysis by using P-V and V-Q curves.
- 2 (a) What is the difference between rotor angle stability and voltage stability?
(b) Explain voltage instability in mature power system.

SECTION - II

- 3 Explain about generator control & protection.
- 4 Explain the system response to power upsets.

SECTION - III

- 5 Discuss in detail about Bonneville Power administration
- 6 Explain about dynamic performance including under voltage shedding.

SECTION - IV

- 7 Explain about reactive compensation loads.
- 8 Describe the following load characteristics that influence the voltage stability
a). Discharging lighting b). Induction motors and c). Electronic power supplies

SECTION - V

- 9 Discuss the following for reactive power compensation and voltage control with neat diagrams:
a).Static VAR system b).Booster transformer
- 10 Explain briefly the steady state static real power stability and steady state reactive power stability.

M.TECH. DEGREE EXAMINATION, SEPTEMBER 2014

M.Tech. II Semester

**ADAPTIVE SIGNAL PROCESSING
(Digital Electronics & Communication Systems)**

Time : 3 hours

Max. Marks :60

*Answer FIVE Questions, Choosing ONE Question from each section
All Questions carry equal marks*

* * *

SECTION - I

- 1 (a) What is Signal Processing? Explain about Adaptive Signal Processing
(b) Where the Adaptive linear combiner is used? Explain
- 2 (a) What are various applications of Adaptive Systems? Explain in detail
(b) How to derive weight vectors of Adaptive linear combiner? Explain

SECTION - II

- 3 (a) What is the physical significance of Wiener-Hopf equation? Explain the processes of Matrix formulation?
(b) Explain about a simple gradient search algorithm? How to obtain its solution
- 4 (a) What is the concept of smoothing and prediction? Explain
(b) What is tap weight? How to compute the tap weight from data matrix R and vector P? Explain

SECTION - III

- 5 (a) What is the process of Gradient search by Newton's method? Explain
(b) A single-weight performance surface has the parameters $\lambda = 0.1$, $J_{\min} = 0$, and $w^* = 2$. Write an expression for this performance surface. If the initial guess for the optimum weight is $w = 0$ and the convergence parameter is $\mu = 4$, what are the first five choices of w ?
- 6 (a) Derive a discrete form of Newton's method using continuous form?
(b) Explain about the Newton's method in multidimensional space

SECTION - IV

- 7 (a) Describe the learning curves for LMS using the necessary theory?
(b) Explain noise in the weight vector solution?
- 8 (a) Define misadjustment in an adaptive process?
(b) Explain how LMS algorithm takes advantage when the performance surface is quadratic?

SECTION - V

- 9 (a) Discuss about estimation of the state using the innovation process?
(b) What is Kalman Gain? Explain the computation of Kalman Gain?
- 10 (a) What is filtered estimation error and conversion factor? Explain
(b) Discuss about filter state –error correlation matrix?

Code : 13MME204

M.TECH. DEGREE EXAMINATION, SEPTEMBER 2014

M.Tech. II Semester

**CUTTING TOOL TECHNOLOGY & TOOL DESIGN
(Advanced Manufacturing Systems)**

Time : 3 hours

Max. Marks :60

*Answer FIVE Questions, Choosing ONE Question from each section
All Questions carry equal marks*

* * *

SECTION - I

1. (a) Explain different cutting tool materials with increasing order of hot hardness and their applications
(b) Distinguish between Normalizing and Annealing.
2. (a) Explain the necessity of heat treatment of steels. Describe the processes of hardening and tempering.
(b) Write short notes on CBN and Cermet cutting tools.

SECTION - II

3. (a) Explain the geometry of single point cutting tool and identify various tool angles with neat sketch.
(b) How insert thickness is determined for carbide tools?
4. (a) Sketch and explain basic elements of twist drill.
(b) What is the importance of rake angle in single point cutting tool?

SECTION - III

5. (a) What are the differences between jigs and fixtures?
(b) What are the general considerations in the design of a drill jig?
6. (a) Explain any two types of fixtures for milling.
(b) Describe the principles of pin location.

[P.T.O]

SECTION - IV

7. (a) In a particular piercing operation, 20 mm holes are to be punched in a brass sheet of 3 mm thick. The max. shear strength of the sheet may be taken as 185 MPa. Design the punch and the die sizes as well as the required punch force.
(b) Explain important parts of a progressive die.
8. (a) What is the largest diameter that can be pierced in a 1.5 mm thick steel plate of 310 MPa shear strength on a 250 KN press? Design the punch and the die dimensions for this operation.
(b) Explain the effect of clearances in sheet metal working with neat sketches.

SECTION - V

9. (a) Explain single and double action draw dies.
(b) Explain bending of sheet metal and how bend allowance is calculated.
10. (a) Explain important elements considered for the design of drawing die.
(b) Explain different types of bending die.

M.TECH. DEGREE EXAMINATION, SEPTEMBER 2014

M.Tech. II Semester

**DATA MINING & DATA WAREHOUSING
(Computer Science & Engineering)**

Time : 3 hours

Max. Marks :60

*Answer FIVE Questions, Choosing ONE Question from each section
All Questions carry equal marks*

SECTION - I

1. (a) Explain the architecture of a typical data mining system.
(b) Discuss the issues regarding data ware house architecture.
2. (a) Differentiate operational database systems and data warehousing.
(b) Discuss about data transformation..

SECTION - II

3. List and describe the five primitives for specifying a data mining task.
4. Explain in detail about data mining query languages.

SECTION - III

5. Write short notes on
 - (a) Measuring the Dispersion of data.
 - (b) Graphic Displays of Basic descriptive data summaries.
6. Explain in detail about Attribute oriented induction for Data characterization.

SECTION - IV

7. (a) What is classification? Discuss issues regarding classification and prediction.
(b) Explain about basic decision tree induction algorithm.
8. (a) Discuss about association rule mining.
(b) What are the approaches for mining multilevel association rules? Explain.

SECTION - V

9. Explain in detail about Density based methods,

10. Write short notes on
 - (a) Mining spatial Databases.
 - (b) Mining Text Databases.
 - (c) Mining the world wide web.

M.TECH. DEGREE EXAMINATION, SEPTEMBER 2014

M.Tech. II Semester**ADVANCED DIGITAL SIGNAL PROCESSING
(Power Systems)**

Time : 3 hours

Max. Marks :60

*Answer FIVE Questions, Choosing ONE Question from each section
All Questions carry equal marks*

SECTION-I

1. State and prove the properties of DFT.
2. Determine the Inverse DTFT for the signal

$$X(e^{j\omega}) = \frac{3 - \frac{1}{4}e^{-j\omega}}{1 - \frac{1}{16}e^{-j2\omega}}$$

SECTION-II

3. Determine the Wiener-Hopt equations for the Linear Transversal Filter.
4. Determine the coefficients $\{h(n)\}$ of a linear phase FIR filter of length $M=15$ which has a symmetric unit sample response and a frequency response that satisfies the condition

$$H_r\left(\frac{2\pi k}{15}\right) = \begin{cases} 1, & k = 0,1,2,3 \\ 0, & k = 4,5,6,7 \end{cases}$$

SECTION-III

5. Define Inverse CWT. State necessary conditions
6. Describe briefly about orthonormal wavelets and general construction of orthonormal MRA.

SECTION-IV

7. Explain the CPU internal bus structure of C24X series DSP controller.
8. Explain the architecture of TMS320C240 DSP controller.

SECTION-V

9. Explain ARM instruction set.
10. Explain the memory addressing modes used by the C2XX instruction set.

M.Tech. II Semester

**DSP PROCESSORS & ARCHITECTURE
(Digital Electronics & Communication Systems)**

Time : 3 hours

Max. Marks :60

*Answer FIVE Questions, Choosing ONE Question from each section
All Questions carry equal marks*

* * *

SECTION - I

- 1 Briefly discuss about the computation of DFT&FFT. How MATLAB is used to compute DFT&FFT with suitable example.
- 2 a). Explain the two approaches that are used to design IIR filter .
b). Given $x(n)=[1,4,8,10,12]$, if $L=3$ find out the interpolated sequence $y(m)$

SECTION - II

- 3 Explain the number formats for signals and coefficients in DSP systems with an example
- 4 a). Briefly discuss about the floating point & block floating point formats
b). Explain suitable D/A errors in DSP implementation.

SECTION - III

- 5 Design an address generation unit for programmable DSP architecture
- 6 Explain in detail the different addressing modes required for the FFT algorithm implementation.

SECTION - IV

- 7 Explain the following algorithms with respect to FFT
a). Butterfly computation b). Bit reversal index generation
- 8 Briefly describe about the implementation of PID controller algorithm in IC54XX processor.

SECTION - V

- 9 Explain in detail how to interface memory and I/O peripherals to Programmable DSP processors
- 10 Explain about the multi channel buffered serial port.

M.TECH. DEGREE EXAMINATION, SEPTEMBER 2014

M.Tech. II Semester**METAL FORMING PROCESSES
(Advanced Manufacturing Systems)**

Time : 3 hours

Max. Marks :60

Answer **FIVE** Questions, Choosing **ONE** Question from each section
All Questions carry equal marks

* * *

SECTION - I

1. (a) What is hot working? Plastic deformation of lead at room temperature is a hot working process. Justify.
(b) The yield strength of a material before plastic deformation is 200 MPa. What is the yield strength of the material if it is cold worked to 20% increment in length if the material follows the law $\sigma = 300\Sigma^{0.3}$? What is the yield strength of material if it is hot worked to same length increment?
2. (a) How are minimum and maximum temperatures determined in hot working process.
(b) In a rod drawing operation a bar of 25 mm diameter and 1m length is reduced to 20 mm diameter. Find the length of the drawn bar and the deformation energy spent in drawing the bar if the flow curve of the material is given by $\sigma = 1400\Sigma^{0.5}$.

SECTION - II

3. (a) Derive the expression for length of contact in terms of draft and roller radius.
(b) The thickness of a plate is to be reduced from 30 mm to 10 mm in successive cold rolling process using identical rolls of diameter 600 mm. if the coefficient of friction between roll plate interface is 0.1, find (a) the maximum reduction possible for each pass (b) Minimum number of passes required (c) Roll strip contact length at maximum reduction (d) Angle of bite.
4. A copper strip of 200 mm wide and 30 mm thickness is to be rolled to a thickness of 25 mm. The roll of radius 300 mm rotates with 100 r.p.m. The average shear strength of work material is 180 MPa. Find the roll strip contact length and roll separating force. Assume that the interface friction is the minimum required friction for the operation.

SECTION - III

5. (a) State the merits and demerits of open die forging compared to impression die forging.
(b) A block of lead 25 mm x 25mm x 150 mm is pressed between two flat dies to a size of 6.25 mm x 100 mm x 150 mm. If uniaxial flow stress is 6.9 MPa and friction coefficient is 0.25. Find (i) Whether sticking condition occurs at the midpoint of the length (ii) What is length at which sticking condition changes to slipping condition (iii) Find the pressures from midpoint to the end of the slab at the intervals of 10 mm.
6. (a) What are different methods of producing metal powders?
(b) Explain about various defects those may occur in forging process along with their causes.

[P.T.O]

SECTION - IV

7. (a) How are the collapsible tubes produced?
(b) With uniform deformation energy method, show that the extension force for ideal deformation is $F = \bar{\sigma}_0 A_0 \ln R$ where $\bar{\sigma}_0$ is mean flow stress flow stress, A_0 is area of the billet and R is the extension ratio.
8. (a) Explain about various parts of the drawing die with their functions.
(b) Find the maximum possible percentage reduction in area of wire in a wire drawing process in case of ideal deformation of a perfectly plastic material.

SECTION - V

9. (a) Explain about the effect of thickness and ductility on minimum bend radius.
(b) Explain about stretch forming process with a neat sketch and also explain why spring back is less in stretch forming.
10. (a) What are limit strains? And explain how those are determined.
(b) Explain about Electromagnetic forming process with a neat sketch.

Code : 13CS12E4

M.TECH. DEGREE EXAMINATION, SEPTEMBER 2014

M.Tech. II Semester

**WEB TECHNOLOGIES
(Computer Science & Engineering)**

Time : 3 hours

Max. Marks :60

*Answer FIVE Questions, Choosing ONE Question from each section
All Questions carry equal marks*

* * *

SECTION - I

- 1 (a) Explain with an HTML document to demonstrate various types of CSS selectors
(b) Describe in detail about SAX.
- 2 (a) Explain frames in HTML with examples.
(b) Write java script for Fibonacci series.

SECTION - II

- 3 Explain about the various interfaces of javax.servlet.
- 4 (a) Describe session tracking in detail.
(b) Explain about reading initialization parameters.

SECTION - III

- 5 (a) Describe about the anatomy of JSP page.
(b) Write short notes on AJAX.
- 6 Write a program to access a database from a JSP page.

SECTION - IV

- 7 (a) Discuss about sharing data between JSP pages.
(b) Describe about error handling and debugging in details with examples.
- 8 Write a simple Bean example to set values and get values by JSP.

SECTION - V

- 9 Explain the differences between ASP and ASP.Net with examples
- 10 Write a program to validate a form in PHP.

Code: 13CS1205

M.TECH. DEGREE EXAMINATION, SEPTEMBER 2014

M.Tech. II Semester

**GRID COMPUTING
(Computer Science & Engineering)**

Time : 3 hours

Max. Marks :60

*Answer FIVE Questions, Choosing ONE Question from each section
All Questions carry equal marks*

* * *

SECTION - I

- 1 Discuss in detail about web service and grid service
- 2 Describe virtual organization

SECTION - II

- 3 Explain the architecture of Grid monitoring architecture. What is the purpose of directory service in GMA?
- 4 Discuss the monitoring systems a) Ganglia b) GridMon

SECTION - III

- 5 Explain the Grid Scheduling with QoS
- 6 Discuss in detail about the Grid Security

SECTION - IV

- 7 Discuss in detail about Data Management Services
- 8 Discuss in detail about Second- Generation Grid portals

SECTION - V

- 9 List any two Grid middlewares and their functionalities in detail
- 10 Explain the architecture of Globus GT3 toolkit with a neat diagram

Code : 13EC1205

M.TECH. DEGREE EXAMINATION, SEPTEMBER 2014

M.Tech. II Semester

**MICRO COMPUTER SYSTEM DESIGN
(Digital Electronics & Communication Systems)**

Time : 3 hours

Max. Marks :60

*Answer FIVE Questions, Choosing ONE Question from each section
All Questions carry equal marks*

* * *

SECTION - I

- 1 A Explain the meaning of the following addressing modes
(i) Mov AX, 50H [BX] [SI] (ii) LAHF (iii) CBW (iv) TEST
(v) JMP 5000H:2000H
- B Explain the register organization of 80286.
- 2 A Explain protected virtual address mode of 80286
- B Draw and explain 8086 architecture.

SECTION - II

- 3 A Explain the use of each the following registers in 80386
(i) Control Register (ii) Debug & Test register
- B Explain the segmentation in 80386
- 4 A Draw and explain paging mechanism of 80386
- B Explain pin configuration of 80386 microprocessor.

SECTION - III

- 5 A Contrast the Pentium pro with 80386 and 80486 microprocessor.
 - B "In what way is Pentium pro an improvement over Pentium." Explain in detail,
 - 6 A Explain special Pentium registers.
 - B Compare dual processor and hyper threaded processor in detail
-

SECTION - IV

- 7 A What is pure code? List some applications of pure code?
B What is memory fragmentation? How can it be reduced?
- 8 What are the means of giving priority to an interrupt system? Explain them in detail

SECTION - V

- 9 A Draw 8087 arithmetic coprocessor control register and explain each control bit.
B Explain the function of each instruction (i) FRNDINT (ii) FCHS (iii) FTST (iv) FCOMI (v) FPTAN
- 10 A Convert decimal number 100.25 to single precision(32 bit) floating point number. List all the conversion steps.
B Draw and explain the internal structure of 8087 arithmetic coprocessor

Code : 13PS1209

M.TECH. DEGREE EXAMINATION, SEPTEMBER 2014

M.Tech. II Semester

**REACTIVE POWER CONTROL
(Power Systems)**

Time : 3 hours

Max. Marks :60

*Answer FIVE Questions, Choosing ONE Question from each section
All Questions carry equal marks*

* * *

SECTION-I

1. Write about magnetizing MVAR requirements of transformer.
2. Explain the importance of synchronous machines and capacitors for reactive power compensation.

SECTION-II

3. What is static VAR controller? explain working of an SVC controller in detail.
4. What is meant by stability of power system, explain

SECTION-III

5. Write short notes on
 - (a) EHV and UV Low tension capacitors,
 - (b) Retrofitting of capacitor banks.
6. Explain the economic justification of reactive power planning.

SECTION-IV

7. Give overall picture of the power requirement in India.
8. What is meant by general lighting? Explain

SECTION-V

9. Write the basic disadvantages by power factor of control and explain the principle of power factor sensing relay.
10. Write short notes on shunt capacitors and tuned capacitor filters.

Code: 13MME205

M.TECH. DEGREE EXAMINATION, SEPTEMBER 2014

M.Tech. II Semester

**SIMULATION MODELING OF MANUFACTURING SYSTEMS
(Advanced Manufacturing Systems)**

Time : 3 hours

Max. Marks :60

*Answer FIVE Questions, Choosing ONE Question from each section
All Questions carry equal marks*

* * *

SECTION - I

1.

(a) Explain the characteristics of various types of simulation models? Discuss their suitability.

(b) What are the different methods involved to analyze the system?

2.

(a) Define the following terms: (i) Consistency (ii) Unbiasedness and (iii) Efficiency

(b) Let X_1, X_2, X_3 and X_4 be independent random variables such that $E(X_i) = \mu$ and $\text{var}(X_i) = \sigma^2$ for $i=1, 2, \dots, 4$. If $Y = (X_1 + X_2 + X_3 + X_4) / 4$ & $Z = (X_1 + X_2 + X_3 + X_4) / 5$ & $T = (X_1 + X_2 + X_3 - X_4) / 4$. Examine whether Y, Z and T are unbiased estimators of μ ? What is the efficiency of Y relative to Z?

SECTION - II

3.

(a) What are the principles adopted for valid simulation modeling?

(b) Explain various techniques for increasing model validity and its credibility.

4.

(a) Explain statistical procedures for developing credible model.

(b) "Selection of right distribution for random elements is essential for simulation results"- Explain.

SECTION - III

5.

(a) List out various algorithms for generating random variates from given distribution and explain any two in detail.

(b) Explain the use of normal random variate for generation of continuous random variate.

6.

(a) Enumerate the differences between simulation languages and simulators.

(b) Write the symbols used in SIMAN along with their significance.

SECTION - IV

7.

(a) Elucidate the various approaches for steady state analysis.

(b) Explain Welch algorithm w.r.to output data analysis.

8.

(a) Explain the role of Batch means method for the output data analysis.

(b) Explain warm-up period and its importance in the output data analysis.

SECTION - V

9.

Assembled television sets are inspected for volume control in an assembly line. The arrival rate of the television set follows Poisson distribution and it is 21 sets per hour. The inspection rate also follows Poisson distribution and it is 25 sets per hour. In front of the inspection station, waiting space is sufficient for a maximum of 6 television sets. Simulate for arrival of 10 television sets and estimate the following:

i) Average waiting number of TV sets in the system.

ii) Average waiting time per TV set in the system.

10.

In Big manufacturing company raw materials are received from various vendors .The transport of these raw materials are done using trucks .Before the raw materials are sent to the stores they are inspected . The inspectors take 6 minutes for inspecting the truck and he can inspect only one truck at a time. The following data is available:

Inter arrival time of truck(minutes)	2	3	4	5	6	8	11	12	14
Frequency	3	6	9	18	20	19	10	8	7

Once the truck is inspected it is sent to the store. Using Montecarlo simulation, determine the following :

- i)Average time before service
- ii)Longest wait of the truck

